

Changeur à panier 12 outils

Korbwechsler 12 WZ

Basket changer 12 tools

DIN 69893 HSK - A32

n = 27000 1/min



Porte-pinces, pinces et écrous E court
Spannzangenhalter, Zangen und Muttern E kurz
Collet chucks, collets and nuts E short

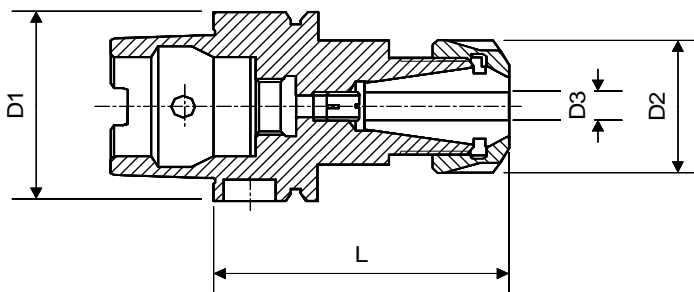

équilibré
ausgewuchtet
balanced

G2.5 à 45'000 1/min
G2.5 bei 45'000 1/min
G2.5 at 45'000 1/min

D1	Art.	L	D2	D3	Pince Spannzange Collet	Ecrou équilibré gewuchtete Mutter balanced Nut	Clé Schlüssel Spanner
HSK - A32	87-32221	50	17	0.5-7	EX12 75-12200 ESX12 75-12300 ET1-12... Ø + DIN, ISO, J	61-12721	-
	87-32222	60	25	0.5-10	EX16 75-16200 ESX16 75-16300 ET1-16... Ø + DIN, ISO, J	61-16721	-

Porte-pinces, pinces et écrous E long
Spannzangenhalter, Zangen und Muttern E lang
Collet chucks, collets and nuts E long

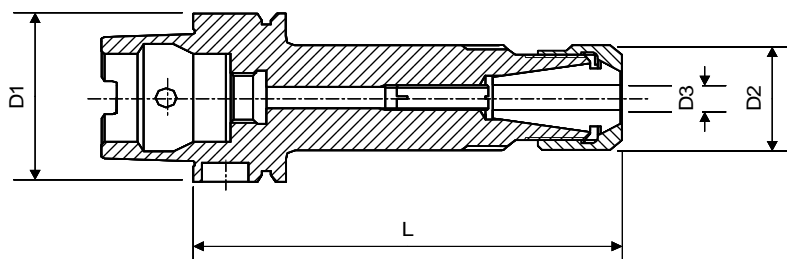

équilibré
ausgewuchtet
balanced

G2.5 à 45'000 1/min
G2.5 bei 45'000 1/min
G2.5 at 45'000 1/min

D1	Art.	L	D2	D3	Pince Spannzange Collet	Ecrou équilibré gewuchtete Mutter balanced Nut	Clé Schlüssel Spanner
HSK - A32	87-32232	100	25	0.5-10	EX16 75-16200 ESX16 75-16300 ET1-16... Ø + DIN, ISO, J	61-16721	-

Porte-fraises pour queue cyl. avec méplat
Fräserhalter für zyl. Schaft mit Mitnahmefläche
Millholder for cylindrical shank with flat

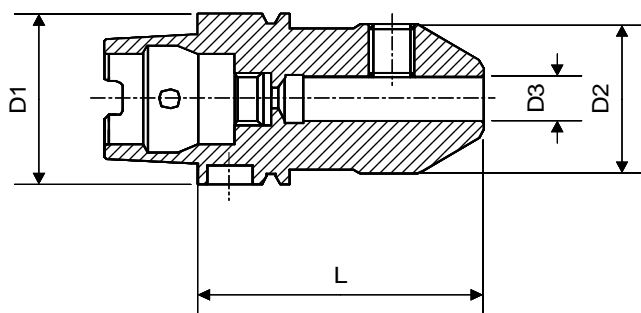

équilibré sur demande
ausgewuchtet auf Anfrage
balanced on request

G6.3 à 45'000 1/min
G6.3 bei 45'000 1/min
G6.3 at 45'000 1/min

D1	Art.	L	D2	D3
HSK - A32	87-32573	71	25	6
	87-32574	76	28	8
	87-32575	78	35	10
	87-32576	82	42	12

Magasin en chaîne 24 outils

Kettenmagazin 24 WZ

Chain magazine 24 tools

DIN 69893 HSK - A40

n = 27000 1/min

Porte-pinces, pinces et écrous E court
Spannzangenhalter, Zangen und Muttern E kurz
Collet chucks, collets and nuts E short



équilibré
ausgewuchtet
balanced

G2.5 à 42'000 1/min
G2.5 bei 42'000 1/min
G2.5 at 42'000 1/min

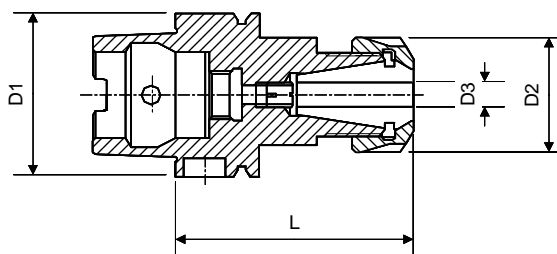

D1	Art.	L	D2	D3	Pince Spannzange Collet	Ecrou équilibré gewichtete Mutter balanced Nut	Clé Schlüssel Spanner
HSK - A40	87-40222	65	25	0.5-10	EX16 75-16200 ESX16 75-16300 ET1-16... Ø + DIN, ISO, J	61-16721	-
	87-40223	71	30.5	0.5-13	EX20 75-20200 ESX20 75-20300 ET1-20... Ø + DIN, ISO, J	61-20721	-
	87-40224	74	42	0.5-16	EX25 75-25200 ESX25 75-25300 ET1-25... Ø + DIN, ISO, J	61-25720	-

Porte-pinces, pinces et écrous E long
Spannzangenhalter, Zangen und Muttern E lang
Collet chucks, collets and nuts E long

équilibré
ausgewuchtet
balanced

G2.5 à 42'000 1/min
G2.5 bei 42'000 1/min
G2.5 at 42'000 1/min

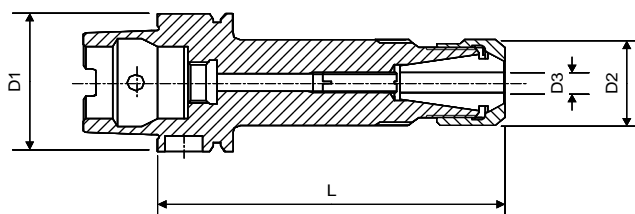

D1	Art.	L	D2	D3	Pince Spannzange Collet	Ecrou équilibré gewichtete Mutter balanced Nut	Clé Schlüssel Spanner
HSK - A40	87-40064	89	19	0.5-7	EX12 75-12200 ESX12 75-12300 ET1-12... Ø + DIN, ISO, J	61-12720	-
	87-40232	100	25	0.5-10	EX16 75-16200 ESX16 75-16300 ET1-16... Ø + DIN, ISO, J	61-16721	-

Porte-fraises pour queue cyl. avec méplat
Fräserhalter für zyl. Schaft mit Mitnahmefläche
Millholder for cylindrical shank with flat

équilibré sur demande
ausgewuchtet auf Anfrage
balanced on request

G6.3 à 42'000 1/min
G6.3 bei 42'000 1/min
G6.3 at 42'000 1/min

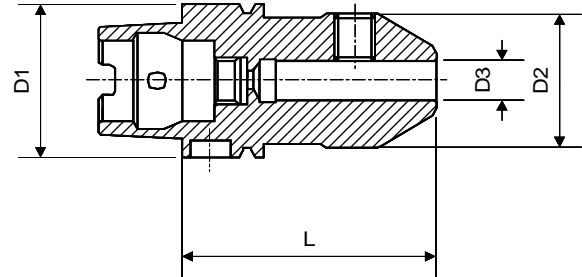

D1	Art.	L	D2	D3
HSK - A40	87-40571	44	22	4
	87-40572	44	22	5
	87-40573	56	25	6
	87-40574	58	28	8
	87-40575	62	35	10
	87-40576	68	42	12
	87-40581	68	44	14
	87-40577	70	48	16
	87-40578	75	52	20

Porte-fraises pour queue cyl. avec méplat
Fräserhalter für zyl. Schaft mit Mitnahmefläche
Millholder for cylindrical shank with flat

équilibré sur demande
ausgewuchtet auf Anfrage
balanced on request

G6.3 à 42'000 1/min
G6.3 bei 42'000 1/min
G6.3 at 42'000 1/min

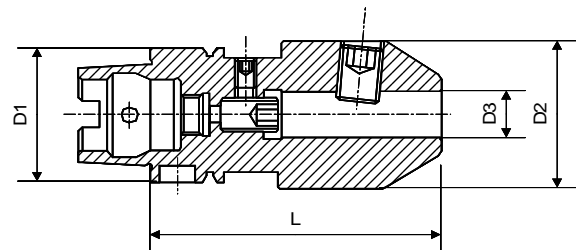

D1	Art.	L	D2	D3
HSK - A40	87-40853	70	25	6
	87-40854	70	28	8
	87-40855	75	35	10
	87-40856	80	42	12
	87-40857	80	44	14
	87-40858	80	48	16

Porte-fraises pour frettage
Schrumpffutter
Shrink-fit millholder

équilibré
ausgewuchtet
balanced

G2.5 à 42'000 1/min
G2.5 bei 42'000 1/min
G2.5 at 42'000 1/min

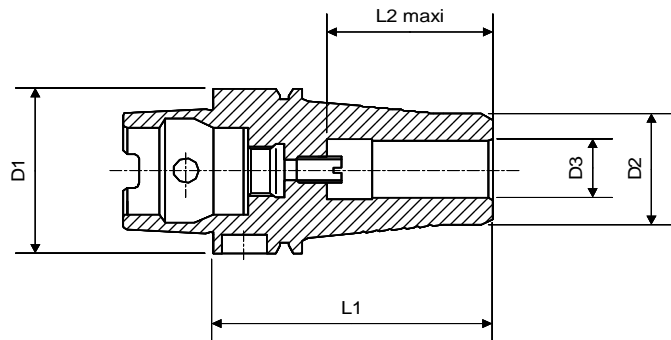

D1	Art.	L1	L2	D2	D3
HSK - A40	87-40644	58	32	19	6
	87-40645	63	37	21	8
	87-40642	63	37	23	10
	87-40647	63	37	25	12
	87-40648	63	37	27	14
	87-40649	66	40	29	16
	87-40650	66	40	31	18
	87-40651	71	45	34	20

Porte-fraises universel
Kombi-Fräserhalter
Universal millholder

non équilibré
nicht ausgewuchtet
not balanced

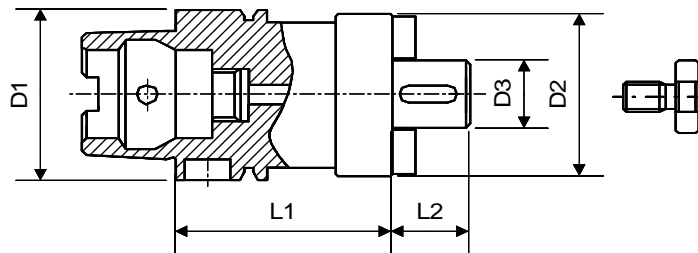

D1	Art.	L1	L2	D2	D3
HSK - A40	87-40501	35	13	28	13
	87-40503	45	17	38	16
	87-40505	50	19	48	22

Tasseau ébauché
Rohling
Blank

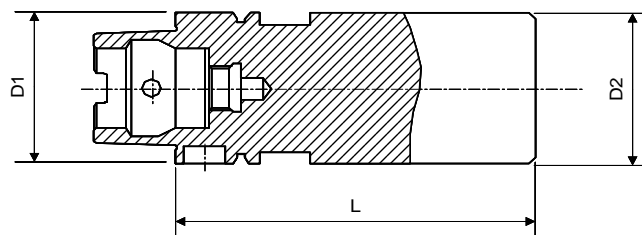

D1	Art.	L	D2
HSK - A40	87-40720	125	40