

PCM

SWISS



PRECISION TOOLING

TOOL HOLDERS FOR CITIZEN A20-VII



www.pcm.ch

www.pcm.ch

EXPERIENCE &
QUALITY

PCM WILLEN S.A.
Z. Industrielle C,
Rte. Du Grammont 101
CH-1844 Villeneuve

Tel: +41(0)21 967 33 66
Fax: +41(0)21 960 38 95
E-Mail: office@pcm.ch





PCM

SWISS



PRECISION TOOLING

CITIZEN A20-VII



BSE-1007

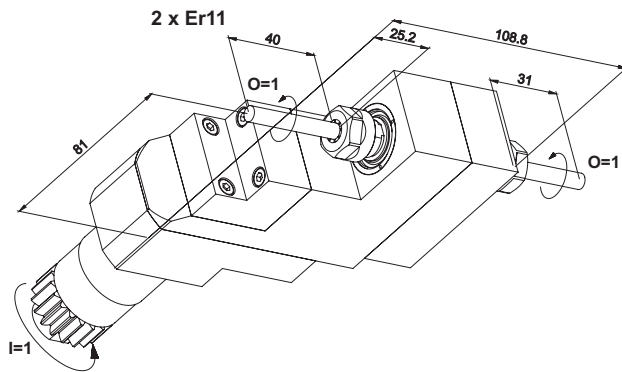

BSE-207

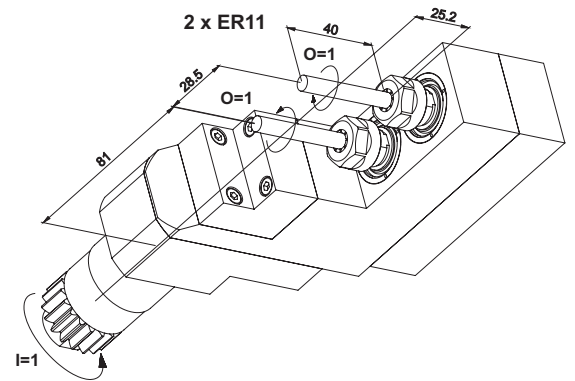

BSE-2007

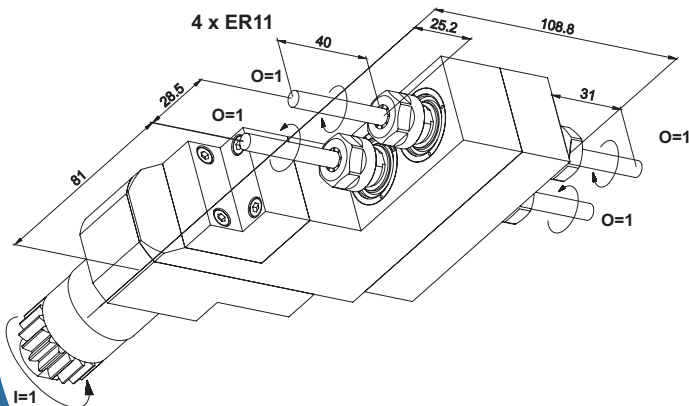

www.pcm.ch



PCM

SWISS



PRECISION TOOLING

CITIZEN A20-VII

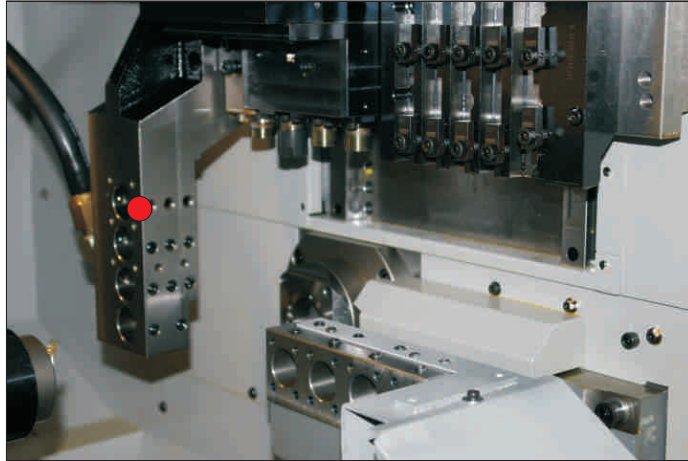

BSW-215

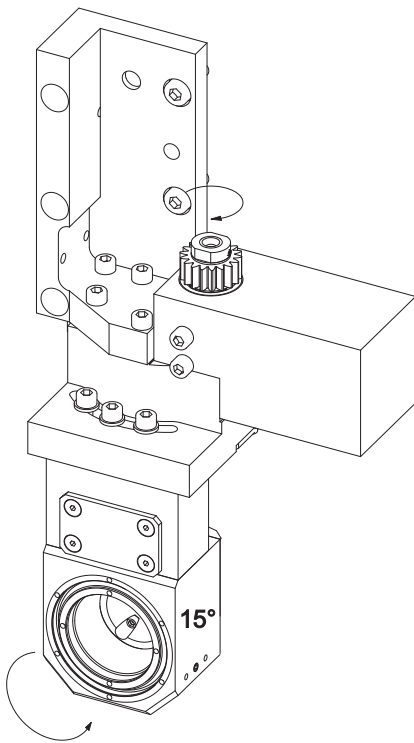

Nur 1 Station ist auswechselbar
1 station seulement est interchangeable

End face drilling Spindle
BSC210

Cross-milling spindle
BSE107
BSE207
BSE1007
BSE2007

4 Rotary Tools for Cross Machining

5 Pos. Turning Tools

www.pcm.ch

Tel: +41(0)21 967 33 66
 Fax: +41(0)21 960 38 95
 E-Mail: office@pcm.ch

PCM WILLEN S.A.
 Z. Industrielle C,
 Rte. Du Grammont 101
 CH-1844 Villeneuve



ESPRIT D'EQUIPE

MAKE THE DIFFERENCE



PCM WILLEN S.A.
Z. Industrielle C,
Rte. Du Grammont 101
CH-1844 Villeneuve
Tel: +41(0)21 967 33 66
Fax: +41(0)21 960 38 95
E-Mail: office@pcm.ch

&
EXPERIENCE
QUALITY

www.pcm.ch

